

EXPLODED VIEW & PARTS LISTING

Air Operated Double Diaphragm Pump

Model: DP-50BFT-HD (XDP)

Part#: 854454



To Purchase:

☎ 800-990-7867

✉ sales@yamadapump.com

📍 Find My Rep

More Information:

▶ YouTube: @yamadapump

🌐 yamadapump.com

Data Sheets | CAD Drawings | Manuals Literature | BOM | Performance Curves

Trial Program

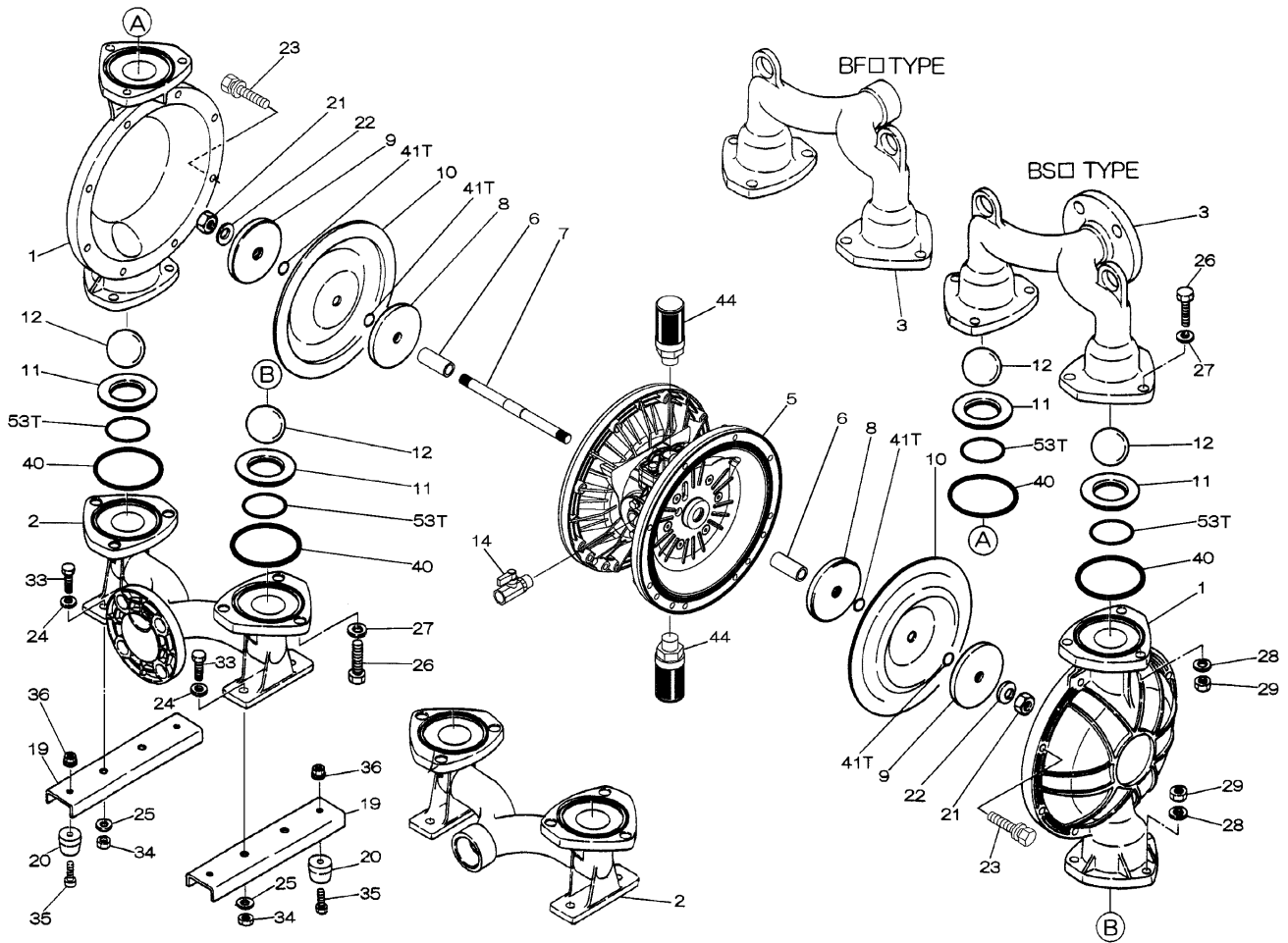

Air Operated Double Diaphragm Pump

804853 Center Body Assembly

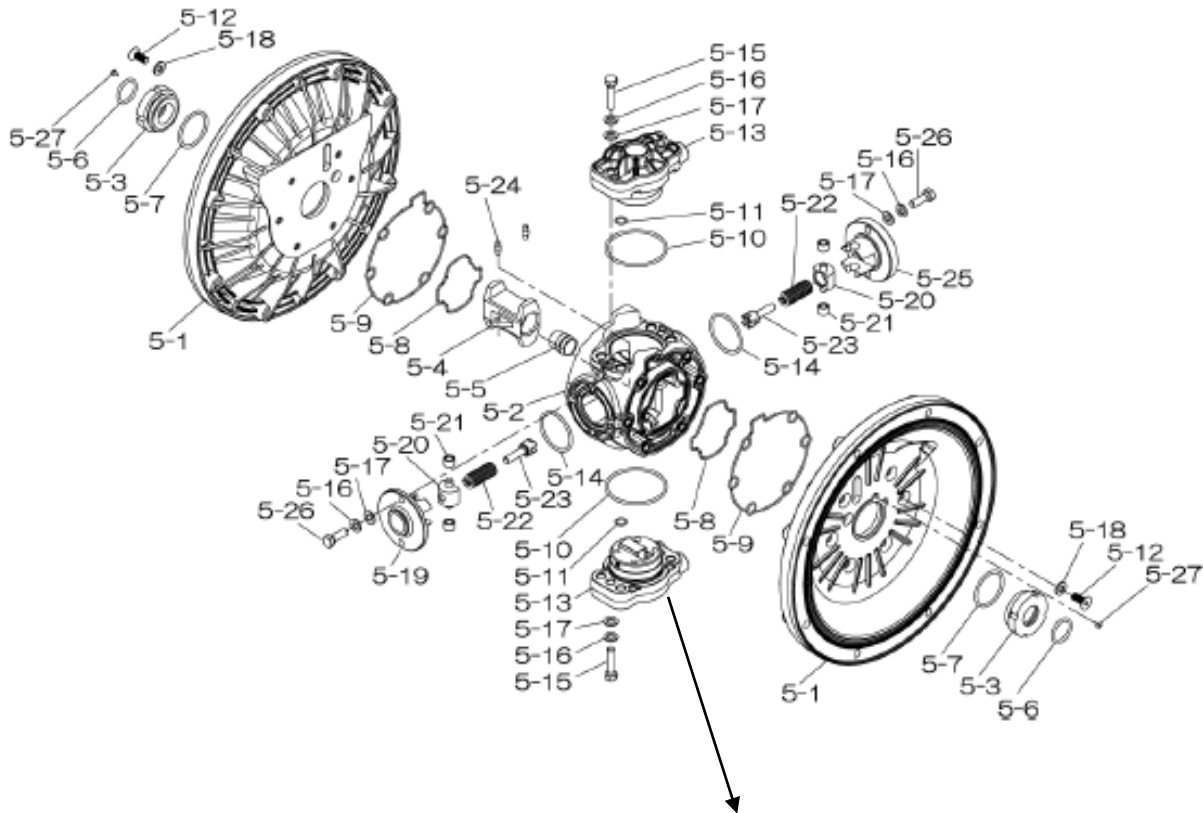

804784 Valve Body Assembly

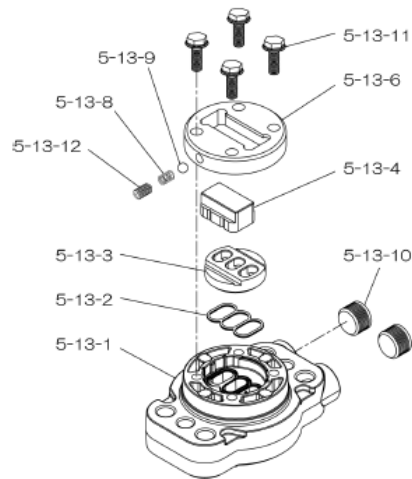

Air Operated Double Diaphragm Pump

REF. No.	PARTS No.	DESCRIPTION	QTY.	REORDER
1	713157	OUT CHAMBER NDP-50FC	2	
2	713169	IN MANIFOLD 50FC FLANGE	1	
3	713166	OUT MANIFOLD 50FC FLANGE	1	
5	804853	CENTER BODY ASSY DP-50T-HD	1	
5- 1	716247	AIR CHAMBER	2	
5- 2	716256	BODY	1	
5- 3	773095	THROAT BEARING	2	
5- 4	716214	SHUTTLE (CS)	1	
5- 5	773047	CENTER ROD GUIDE	1	
5- 6	640023	O RING 24.6MM X 3.6MM	2	
5- 7	640133	O RING	2	
5- 8	773040	GASKET	2	
5- 9	773041	GASKET	2	
5-10	640138	O RING (64.5X3.0MM)	2	
5-11	640007	O RING 9.5MM X 2.0MM	8	
5-12	683812	M8X1.25X20 FLAT SOCKET	12	
5-13	804784	VALVE BODY ASSY	2	
5-13- 1	715244	VALVE BODY(H40.50.80)	1	
5-13- 2	773042	GASKET	1	
5-13- 3	716246	SEAT (CS)	1	
5-13- 4	773425	BLOCK	1	
5-13- 6	773426	GUIDE PLATE	1	
5-13- 8	706612	SPRING INK	1	
5-13- 9	686271	BALL	1	
5-13-10	772934	PLUG 20/25-PP	2	
5-13-11	602300	TAPPING BOLT M6X1X16	4	
5-13-12	610025	HEX. SOCKET HEAD SCREW	1	
5-14	640134	O RING 44.5MM X 3MM	2	
5-15	611153	BOLT M8X1.25X35 HEX FT	4	
5-16	631420	SPRING WASHER M8 ZINC	8	
5-17	631013	WASHER FLAT M8 ZINC DI	8	
5-18	684987	WASHER 40/50/80 NEW	12	
5-19	716249	RETAINER	1	
5-20	713620	SPRING GUIDE	2	
5-21	773067	BUSH	4	
5-22	684537	SPRING	2	
5-23	714446	TRIP ARM	2	
5-24	700231	PIN	2	
5-25	716216	RETAINER	1	
5-26	611149	BOLT M8X1.25X25 FT ZIN	4	
5-27	686337	TAPPING SCREW	2	

6	716399	CENTER BUSH(H4050)	2	
7	716404	CENTER ROD(H4050)	1	
8T	707822	CENTER DISK 50T INNER	2	
9	707823	CENTER DISK	2	
10	770815	DIAPHRAGM (PTFE) 50	2	
11	711909	VALVE SEAT 50AL	4	
12	770693	BALL 50T -63MM PTFE	4	
14	684322	BALL VALVE 50/80 3/4"	1	
19	711928	BASE 50	2	
20	771402	FOOT RUBBER 40/50/80&2	4	
21	706128	NUT M16X1.50 SS	2	
22	682740	WASHER M16 SS CONICAL	2	
23	686044	BOLT	16	
24	631174	WASHER FLAT M10 ZINC	4	
25	631937	WAVE WASHER M10	20	
26	621202	BOLT M12X1.75X50 ZINC	12	
27	631175	WASHER FLAT M12 ZINC D	12	
28	631938	WAVE WASHER	12	
29	628014	NUT M12X1.75 CT ZINC	12	
33	621175	BOLT M10 X 30 FT ZY	4	
34	628013	NUT M10 X 1.5 ZINC DIN	4	
35	611149	BOLT M8X1.25X25 FT ZIN	4	
36	682273	NUT W/ FLANGE M8 X 1.2	4	
40	643069	O RING 103 X6 M PTFE	4	
41T	643015	O RING 15.8MM X 2.4MM	4	
44	804697	MUFFLER 20/25PP NEW	2	
53T	643139	O RING PTFE	4	
KIT	K50-MT	LIQUID SIDE		
KIT	K45-AM-DP-HD	AIR MOTOR		

Torque Requirements:

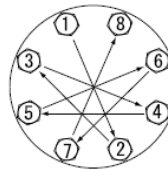

Tightening torque for center rod and out chambers.
Center Rod 43 ft-lbf {60 N-m}
Out Chambers 29 ft-lbf {40 N-m}

Tightening torque for manifold retainer bolts.
BFT 18 ft-lbf {25 N-m}

General Tools:

- Socket wrench - 24mm
- Hexagonal box wrench - 5mm, 6mm
- Open-end wrenches - 19mm, 24mm
- Phillips head screw driver

Special Tools:

- Socket (804129) for a guide to remove the throat bearing (sold separately)

Miscellaneous:

- Assembly Oil - Turbine oil none additional class 1 (equivalent to ISA VGA32 grade)
- Nuts - M16 x 1.5
- Thread locker
- Urea grease grade (NLGI) No. 2, Shell Alvania Grease S1

Customer Notes

Model #: _____
Description: _____
Serial #: _____
Date Installed: _____
Department Location: _____
Tag/Project: _____